

Nože
Výměnné díly
Příslušenství

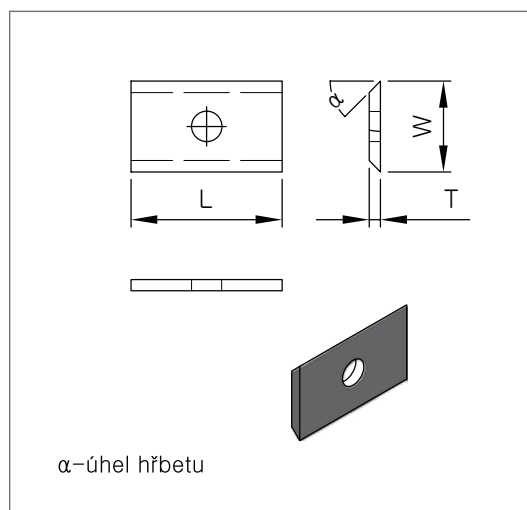

07



L mm	W mm	T mm	α°	Použití	ID No.
7,5	12	1,5	35	univerzální	1200712150
9,6	12	1,5	35		1200912150
10,5	12	1,5	35		1201012150
11	12	1,5	35		1201112150
13	12	1,5	35		1201312150
15	12	1,5	35		1201512150
15,7	12	1,5	35		1201512151
17	12	1,5	35		1201712150
18	12	1,5	35		1201812150
19	12	1,5	35		1201912150
20	12	1,5	35		1202012150
24,7	12	1,5	35		1202412150

L mm	W mm	T mm	α°	Použití	ID No.
7,5	12	1,5	45	masiv	1100712150
15	12	1,5	45		1101512150
20	12	1,5	45		1102012150
7,5	12	1,5	45		1100712151
9,6	12	1,5	45		1100912150
15	12	1,5	45		1101512151
20	12	1,5	45	1102012151	

L mm	W mm	T mm	α°	Použití	ID No.
7,5	12	1,5	35	MDF	1300712150
9,6	12	1,5	35		1300912150
15	12	1,5	35		1301512150
20	12	1,5	35		1302012150

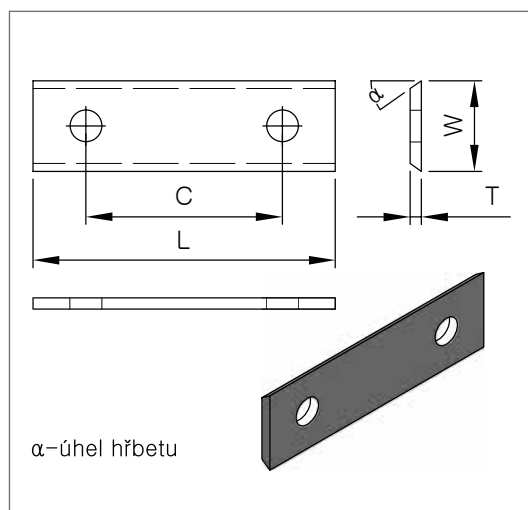

L mm	W mm	T mm	C mm	α°	Použití	ID No.
24,7	12	1,5	14	35	univerzální	1202412151
30	12	1,5	14	35		1203012150
40	12	1,5	26	35		1204012150
50	12	1,5	26	35		1205012150
60	12	1,5	26	35		1206012150

L mm	W mm	T mm	C mm	α°	Použití	ID No.
30	12	1,5	14	45	masiv	1103012150
60	12	1,5	26	45		1106012150
30	12	1,5	14	45		1103012151
40	12	1,5	26	45		1104012151
50	12	1,5	26	45		1105012151
60	12	1,5	26	45		1106012151

L mm	W mm	T mm	C mm	α°	Použití	ID No.
30	12	1,5	14	35	MDF	1303012150
40	12	1,5	26	35		1304012150
50	12	1,5	26	35		1305012150
60	12	1,5	26	35		1306012150

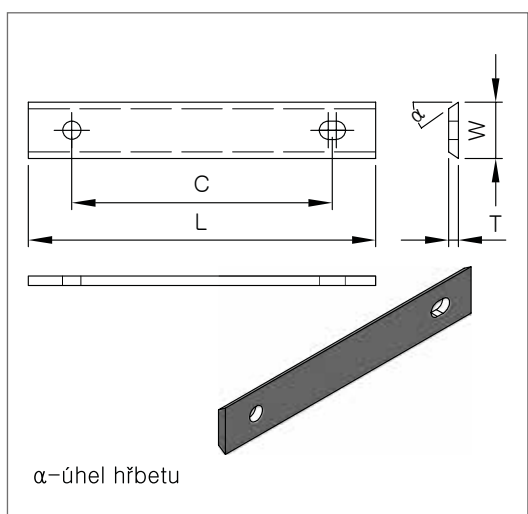

L mm	W mm	T mm	C mm	α°	Použití	ID No.
80	13	2,2	60	35	univerzální	1208013220
100	13	2,2	60	35		1210013220
120	13	2,2	60	35		1212013220

L mm	W mm	T mm	C mm	α°	Použití	ID No.
80	13	2,2	60	45	masiv	1108013221

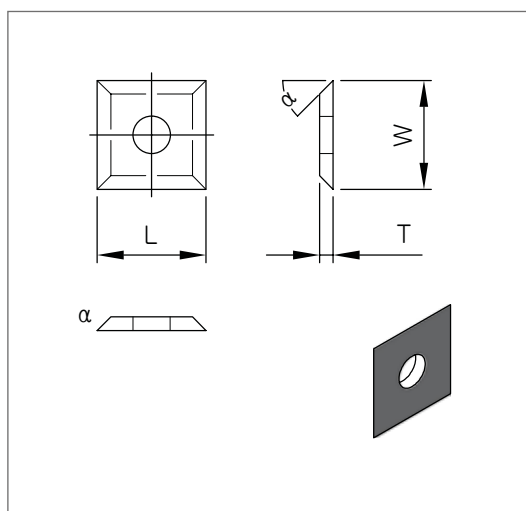

L mm	W mm	T mm	α°	Použití	ID No.
10,5	10,5	1,5	35	univerzální	2201010150
12	12	1,5	35		2201212150
17	17	2	35		2201717200
19	19	2	35		2201919200

L mm	W mm	T mm	α°	Použití	ID No.
12	12	1,5	45	masiv	2101212150

L mm	W mm	T mm	α°	Použití	ID No.
12	12	1,5	35	MDF	2301212150

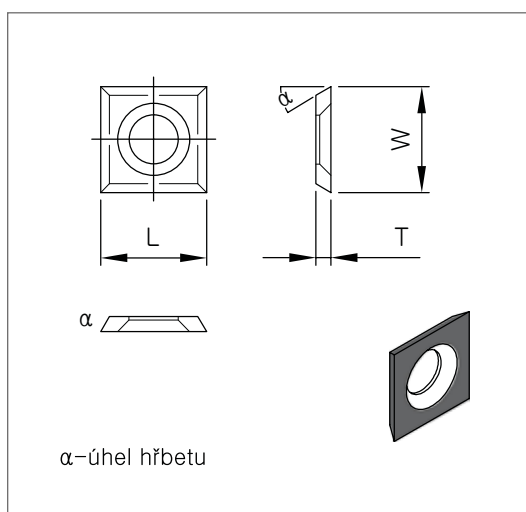

L mm	W mm	T mm	α°	Použití	ID No.
13,6	13,6	2	45	univerzální	2101313200
14	14	1,2	30		2201414120
14	14	2	30		2201414200

L mm	W mm	T mm	α°	Použití	ID No.
14	14	2	30	masiv	2101414200
14,3	14,3	2,5	35		2101414250

L mm	W mm	T mm	α°	Použití	ID No.
14	14	2	30	MDF	2301414200

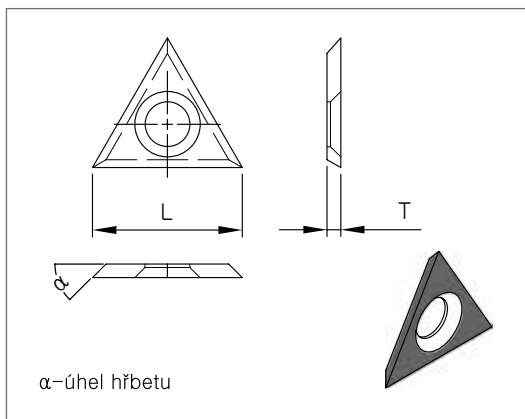

L mm	T mm	α°	Použití	ID No.
22	2	30	univerzální	2102222200

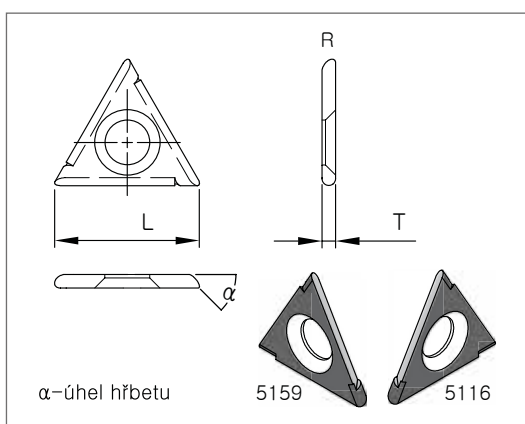

L mm	T mm	α°	R	Použití	ID No.
22	2	30	1	UNI	5159
22	2	30	1	UNI	5116

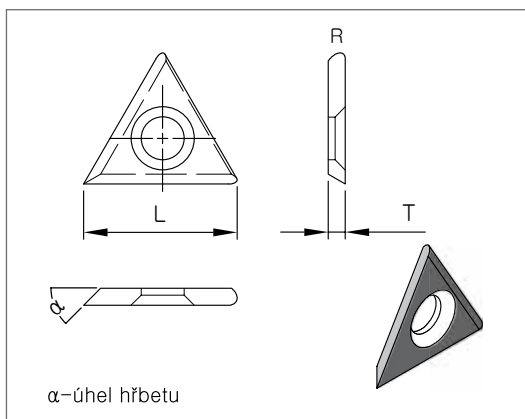

L mm	T mm	α°	R	Použití	ID No.
22	2,5	30	1,5	UNI	RG03M

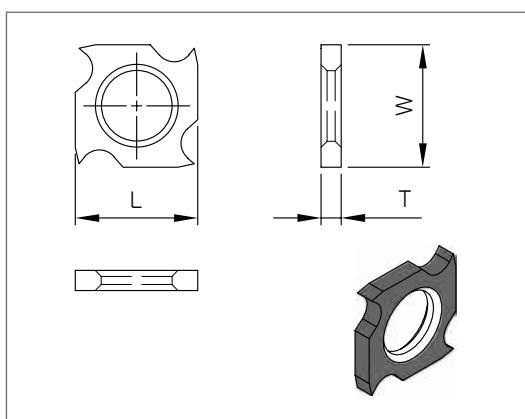

L mm	W mm	T mm	Použití	ID No.
18	18	1,95	univerzální	3401818190
18	18	2,5		3401818250
18	18	2,95		3401818290
18	18	3,7		3401818370
18	18	4		3401818400

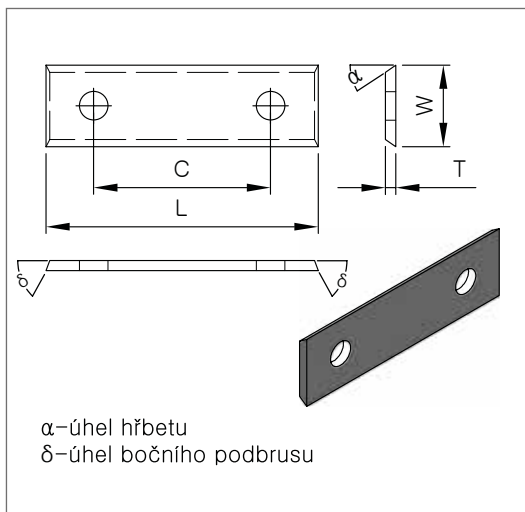

L mm	W mm	T mm	C mm	α°	δ°	Použití	ID No.
29,5	9	1,5	14	35	20	univerzální	2202909150
29,5	12	1,5	14	35	20		2202912150
49,2	9	1,5	26	35	20		2204909150
49,2	12	1,5	26	35	20		2204912150
59,2	12	1,5	26	35	20		2205912150

L mm	W mm	T mm	C mm	α°	Použití	ID No.
29,5	12	1,5	14	35	MDF	2302912150
49,2	12	1,5	26	35		2304912150
59,2	12	1,5	26	35		2305912150

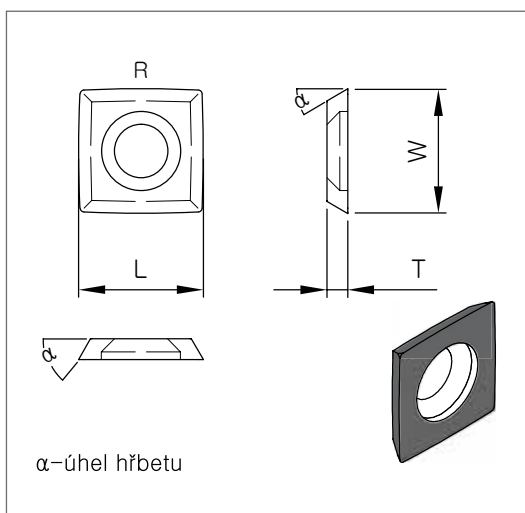

L mm	W mm	T mm	R mm	α°	Použití	ID No.
15	15	2,5	150	30	univerzální	2101515255

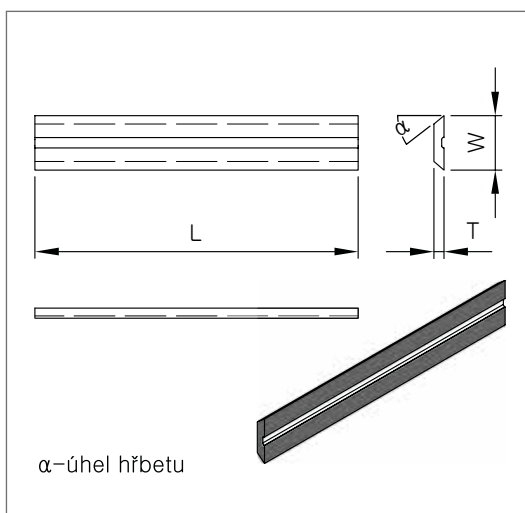

L mm	W mm	T mm	ID No. UNI	ID No. MASIV
7.7	8.0	1.5	4200708150	4100708150
9.7	8.0	1.5	4200908150	4100908150
11.7	8.0	1.5	4201108150	4101108150
14.7	8.0	1.5	4201408150	4101408150
19.7	8.0	1.5	4201908150	4101908150
24.7	8.0	1.5	4202408150	4102408150
30.0	8.0	1.5	4203008150	4103008150
35.0	8.0	1.5	4203508150	4103508150
40.0	8.0	1.5	4204008150	4104008150
45.0	8.0	1.5	4204508150	4104508150
50.0	8.0	1.5	4205008150	4105008150
60.0	8.0	1.5	4206008150	4106008150
70.0	8.0	1.5	4207008150	4107008150
80.0	8.0	1.5	4208008150	4108008150
100.0	8.0	1.5	4210008150	4110008150
120.0	8.0	1.5	4212008150	4112008150

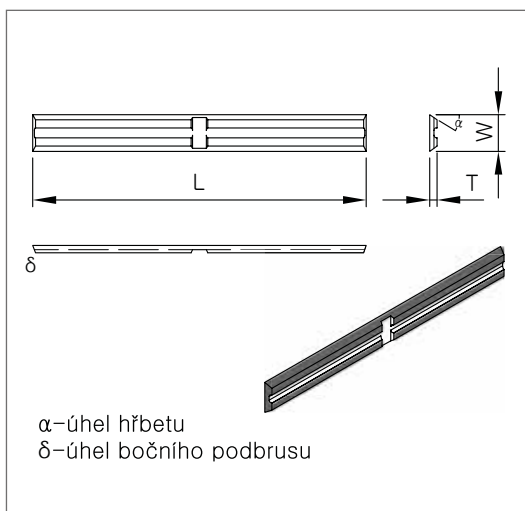

L mm	W mm	T mm	α°	δ°	Použití	ID No.
20	4,1	1,1	35	20	univerzální	5202004110
20	5,5	1,1	35	20		5202005110
25	5,5	1,1	35	20		5202505110
30	5,5	1,1	35	20		5203005110
40	5,5	1,1	35	20		5204005110
50	5,5	1,1	35	20		5205005110

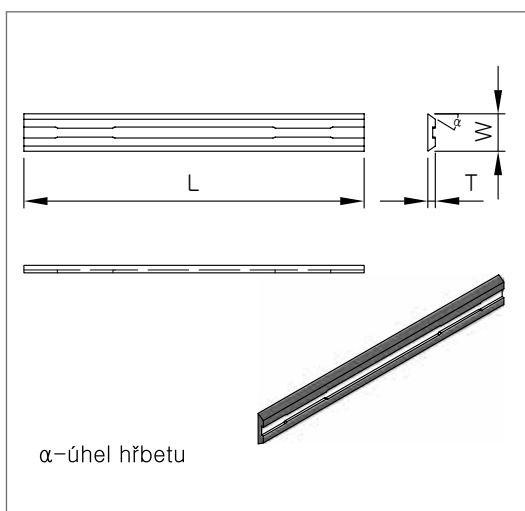

L mm	W mm	T mm	α°	Použití	ID No.
75,5	5,5	1,1	35	univerzální	5107505113
80,5	5,9	1,2	40		5108005123
82	5,5	1,1	35		5108205113

// Výměnná břitová destička – systém StabilHead (DP-VBD)

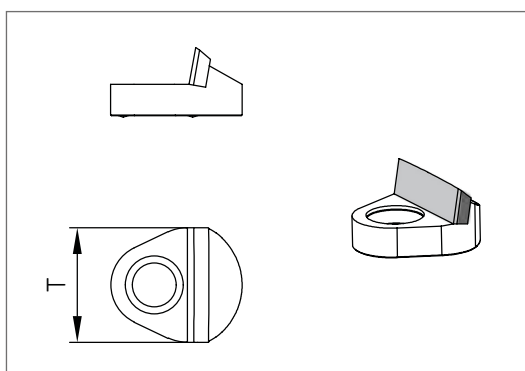

T mm	Použití	ID No.
13.8	systemy StabilHead	970400

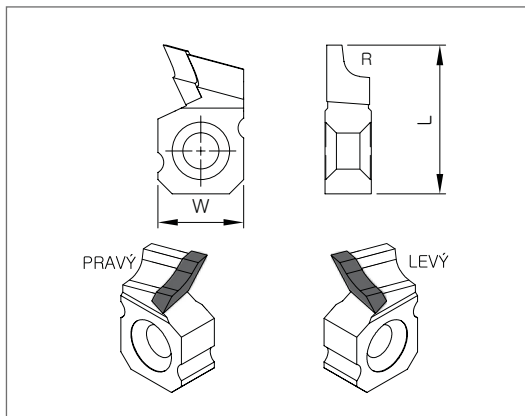

L mm	W mm	R mm	ID No. L	ID No. P
26	15	2	261020	261120
26	15	2,5	261025	261125
26	15	3	261030	261130
26	15	4	261040	261140
26	15	5	261050	261150

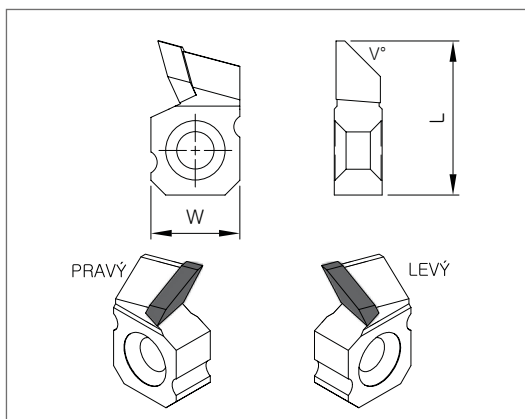

L mm	W mm	V°	ID No. L	ID No. P
26	15	45	262045	262145

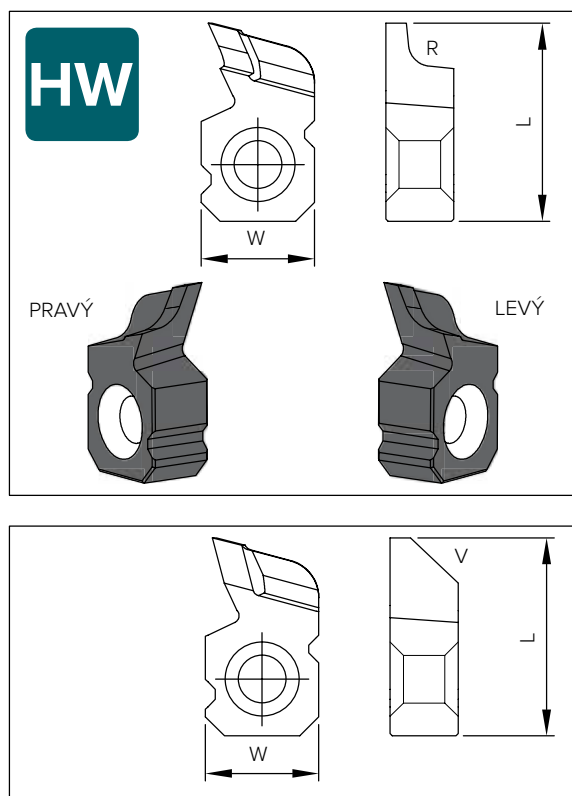
**TECHNICKÉ PARAMETRY**

Celotvrdokovové výměnné břitové destičky
 Plný 1/4 kruh s oboustranným úhlovým výběhem
 Řezná část axiálně naklopena pro vyšší kvalitu řezu
 Při záměně zaoblení dodržují nulové linie

OBRÁBĚNÝ MATERIÁL

tvrdé i měkké dřevo

L mm	W mm	R mm	ID No. L	ID No. R
26,2	15	R1	361010	361110
26,2	15	R2	361020	361120
26,2	15	R2,5	361025	361125
26,2	15	R3	361030	361130
26,2	15	R4	361040	361140
26,2	15	R5	361050	361150

L mm	W mm	V°	ID No. L	ID No. R
26,2	15	45°	362045	362145

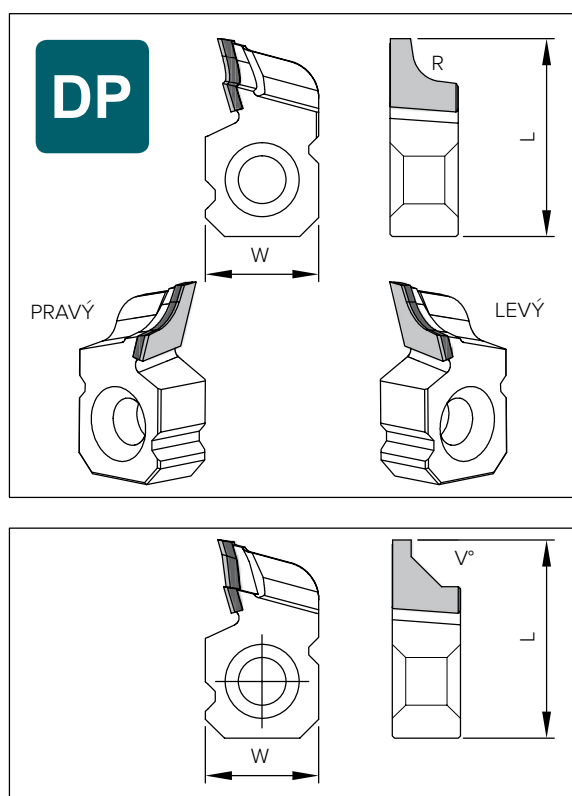
**TECHNICKÉ PARAMETRY**

DP výměnné břitové destičky
 Plný 1/4 kruh s oboustranným úhlovým výběhem
 Řezná část axiálně naklopena pro vyšší kvalitu řezu
 Při záměně zaoblení dodržují nulové linie
 DP destičky lze zaměnit za HW

OBRÁBĚNÝ MATERIÁL

tvrdé dřevo, MDF, DTD, HPL

L mm	W mm	R mm	ID No. L	ID No. R
26,2	15	R1	371010	371110
26,2	15	R2	371020	371120
26,2	15	R2,5	371025	371125
26,2	15	R3	371030	371130
26,2	15	R4	371040	371140
26,2	15	R5	371050	371150

L mm	W mm	V°	ID No. L	ID No. R
26,2	15	45°	372045	372145

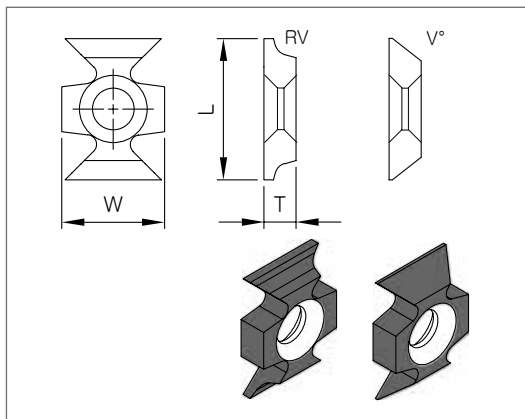

W mm	L mm	T mm	R mm	V°	Typ	Použití	ID No.
22	16	5		45	TKM	Univerzální	3401622500
22	16	5	1		TKM		3401622501
22	16	5	1,5		TKM		3401622502
22	16	5	2		TKM		3401622503
22	16	5	2,5		TKM		3401622504
22	16	5	3		TKM		3401622505

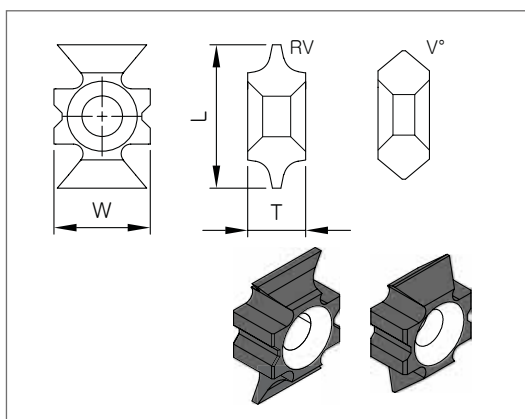

W mm	L mm	T mm	R mm	V°	Typ	Použití	ID No.
20	15	8		45	TKM 11/0	Univerzální	3401520800
22,3	15	7,3	1		TKM 13/0		3401522730
22,3	15	9	1		TKM 13/1		3401522900
20	15	7	1,5		TKM 12/4		3401520700
18,3	15	7,3	2		TKM 12/3		3401518730
20	15	7,3	2		TKM 12/3		3401520730
20	15	9	3		TKM 12/1		3401520900
22,3	15	9	3		TKM 12/0		3401522903
22,3	15	10	3		TKM 12/5		3401522100

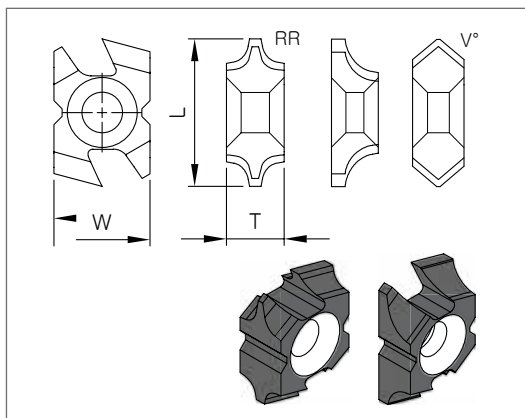

W mm	L mm	T mm	R mm	V°	Typ	Použití	ID No.
23	15	8		45	TKM 21/0	Univerzální	3401523800
23	15	7	1,5		TKM 22/4		3401523700
23	15	7,3	2		TKM 22/3		3401523730
23	15	9	3		TKM 22/0		3401523900
23	15	9	3		TKM 22/5		3401523905
23	15	9	3		TKM 22/1		3401523901
25,7	15	7,3	5		TKM 24/0		3401525730
25,7	15	7,3	5		TKM 24/1		3401525731

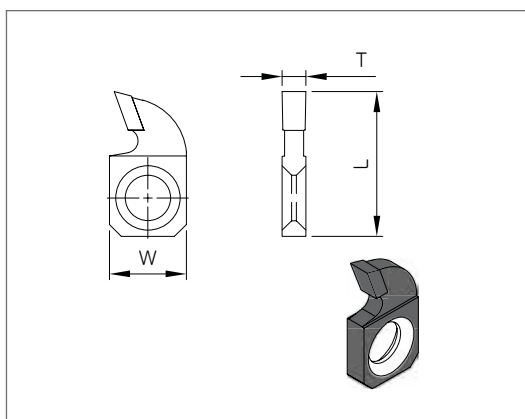

L mm	W mm	T mm	Použití	ID No.
24,5	13	4	Univerzální	3402413400
24,5	13	5		3402413500

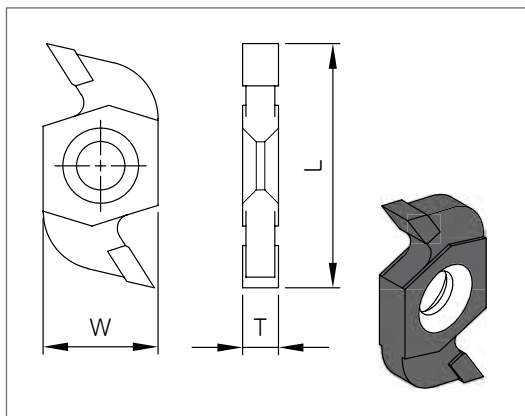

L mm	W mm	T mm	Použití	ID No.
34	16	3,2	Univerzální	3403416320
34	16	4		3403416400
34	16	5		3403416500

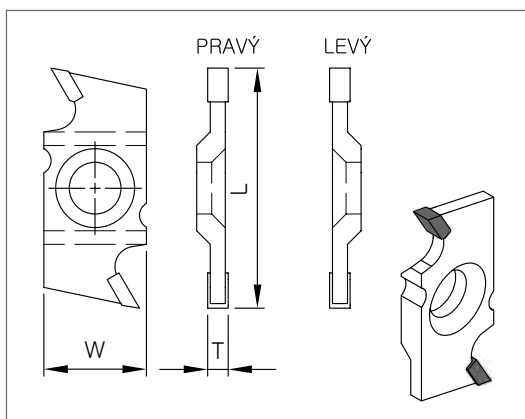

L mm	W mm	T mm	Použití	ID No. L	ID No. P
35,2	15	3	Univerzální	139833	139834

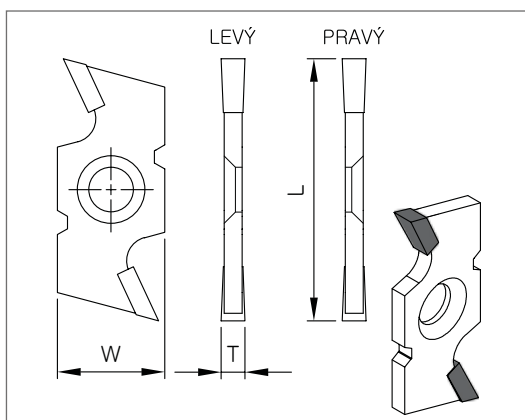

L mm	W mm	T mm	Použití	ID No. L	ID No. P
44	18	3,2	Univerzální	239833	239834
44	18	4		239835	239836

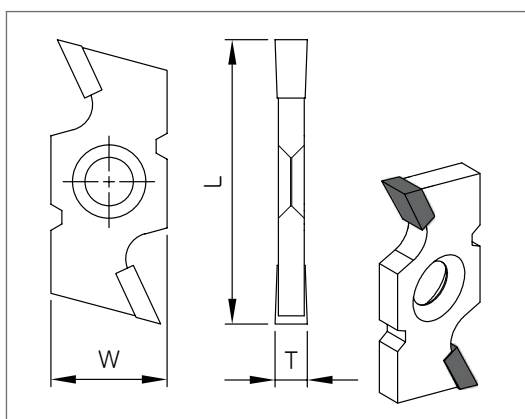

L mm	W mm	T mm	Použití	ID No.
44	18	5	Univerzální	239837
44	18	6		239838
44	18	6,5		239839
44	18	8		239840

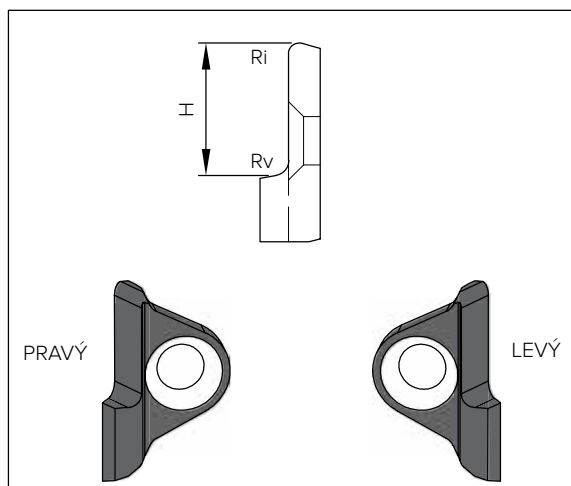

TECHNICKÉ PARAMETRY

Celotvrdkovové výměnné břitové destičky
 Plný 1/4 kruh s oboustranným úhlovým výběhem
 Řezná část axiálně naklopena pro vyšší kvalitu řezu
 Maximální hloubka falce H = 18 mm, Ri max = 1,5 mm, Rv max = 3 mm

H mm	Ri mm	Rv mm	ID No. L	ID No. R
8	1	2	007161008020	007171008020
8	1	2,5	007161008025	007171008025
8	1	3	007161008030	007171008030
10	1	2	007161010020	007171010020
10	1	2,5	007161010025	007171010025
10	1	3	007161010030	007171010030
12	1	2	007161012020	007171012020
12	1	2,5	007161012025	007171012025
12	1	3	007161012030	007171012030
15	1	2	007161015020	007171015020
15	1	2,5	007161015025	007171015025
15	1	3	007161015030	007171015030
18	1	2	007161018020	007171018020
18	1	2,5	007161018025	007171018025
18	1	3	007161018030	007171018030
8	1,5	2	007161508020	007171508020
8	1,5	2,5	007161508025	007171508025
8	1,5	3	007161508030	007171508030
10	1,5	2	007161510020	007171510020
10	1,5	2,5	007161510025	007171510025
10	1,5	3	007161510030	007171510030
12	1,5	2	007161512020	007171512020
12	1,5	2,5	007161512025	007171512025
12	1,5	3	007161512030	007171512030
15	1,5	2	007161515020	007171515020
15	1,5	2,5	007161515025	007171515025
15	1,5	3	007161515030	007171515030
18	1,5	2	007161518020	007171518020
18	1,5	2,5	007161518025	007171518025
18	1,5	3	007161518030	007171518030

! V případě zájmu lze dodat i na hloubku falce v rozmezí 6 – 18 mm.

Upínací šroubek

ID No.

M 6x14 TX20

710068

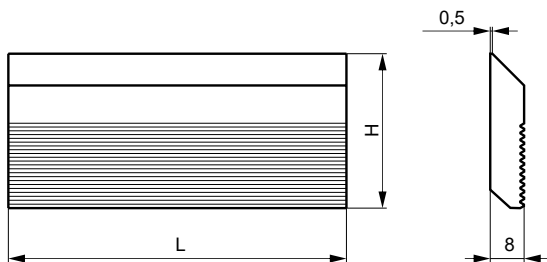

L mm	H mm	ID No. HS 6% W
40	40	030289
40	50	030307
40	60	030326
40	70	030345
50	40	030290
50	50	030308
50	60	030327
50	70	030346
60	40	030291
60	50	030309
60	60	030328
60	70	030347
70	40	030292
70	50	030310
70	60	030329
70	70	030348
80	40	030293
80	50	030311
80	60	030330
80	70	030349
100	40	030295
100	50	030313
100	60	030332
100	70	030351
130	40	030297
130	50	030315
130	60	030334
130	70	030353
150	40	030298
150	50	030316
150	60	030335
150	70	030354
180	40	030300
180	50	030318
180	60	030337
180	70	030356

POUŽITÍ

ocelový blanket se zadním rýhováním s napájenou břitovou destičkou ze slinutého karbidu
ekonomicky výhodný systém pro bezpečnostní frézovací hlavy s podstatným nárůstem životnosti nožů

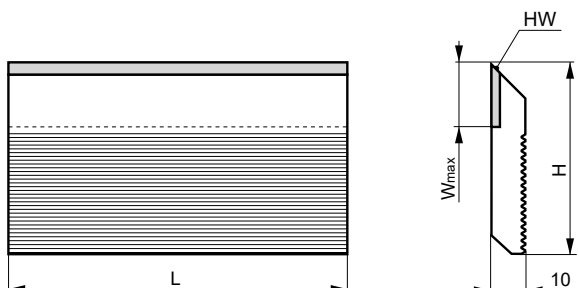

L mm	H mm	ID No.		
		W max. 14mm	W max. 20mm	W max. 25mm
40	40	103230	103249	
60	40	103231	103250	
80	40	103232	103251	
100	40	103233	103252	
130	40	103234	103253	
150	40	103235	103254	
180	40	103236	103255	
200	40	103237	103256	
230	40	103238	103257	
260	40	103239	103258	
310	40	103240	103259	
40	50	103242	030254	
60	50	030255	103261	
80	50	030256	103262	
100	50	030257	103263	
130	50	030258	103264	
150	50	103243	103265	
180	50	030260	103266	
200	50	103244	103267	
230	50	103245	103268	
260	50	030262	103269	
310	50	103246	103270	
560	50	103247	103271	
40	60		030267	103300
60	60		030268	103301
80	60		103273	030269
100	60		103274	030270
130	60		103275	030271
150	60		030272	103302
180	60		030273	103303
200	60		103296	103304
230	60		103297	103305
260	60		030275	103306
310	60		103298	103307
560	60		103299	103308

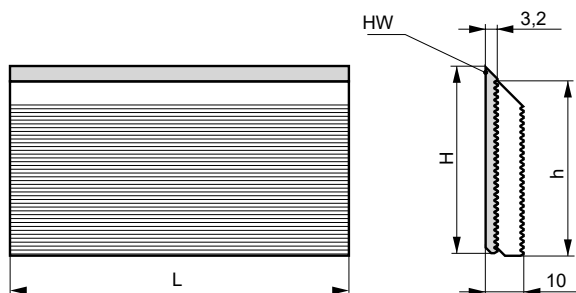

POUŽITÍ

HW blanket se zadním rýhováním a oboustranně rýhované ocelové opěrky ekonomicky výhodný systém pro bezpečnostní frézovací hlavy s podstatným nárůstem životnosti nožů

jakost HW blanketu MG18 a T10MG pro tvrdé dřevo

jakost T04F pro univerzální použití

jakost T03SMG pro obrábění MDF

systém rýhování je konstruován až do 12 000 ot/min

L mm	H mm	h mm	ID No. T10MG	ID No. T04F	ID No. T03SMG	ID No. Opěrka
40	38	35	743933	724082	724080	724090
50	38	35	743934	743924	743925	743957
60	38	35	743935	724115	724113	724123
80	38	35	743936	724148	724146	724156
100	38	35	743937	723949	723947	723957
120	38	35	743938	723982	723980	723990
130	38	35	743939	724016	724014	724024
150	38	35	743940	724049	724047	724057
170	38	35	743962	743961	743960	745837
180	38	35				733020
230	38	35				733021
240	38	35				733022
40	50	47	743941	724093	724091	724101
50	50	47	743942	743927	743928	743958
60	50	47	743943	724126	724124	724134
80	50	47	743944	724159	724157	724167
100	50	47	743945	723960	723985	723968
120	50	47	743946	723993	723991	724001
130	50	47	743947	724027	724025	724035
150	50	47	743948	724060	724058	724068
170	50	47	743966	743965	743964	745838
180	50	47				733023
230	50	47				733024
240	50	47				733025
40	60	57	743949	724104	724102	724112
50	60	57	743950	743931	743932	743959
60	60	57	743951	724137	724135	724145
80	60	57	743952	724170	724168	724178
100	60	57	743953	723971	723969	723979
120	60	57	743954	724004	724002	724012
130	60	57	743955	724038	724036	724046
150	60	57	743956	724071	724069	724079
170	60	57	743970	743969	743968	745839
180	60	57				733026
230	60	57				733027
240	60	57				733028

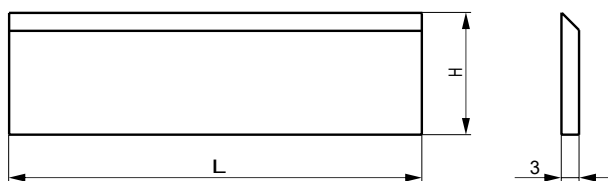

L mm	H mm	ID No. HSS 18%W	ID No. HS
60	30	111908	8118603
60	35	111944	8118605
80	30	111913	8118803
80	35	111945	8118805
100	30	111914	8118103
100	35	111946	8118105
120	30	111916	8118123
120	35	111948	8118125
130	30	111917	8118133
130	35	111949	8118135
150	30	111918	8118153
150	35	111950	8118155
160	30	111919	8118163
160	35	111951	8118165
170	30	111920	8118173
170	35	111952	8118175
180	30	111921	8118183
180	35	111953	8118185

L mm	H mm	ID No. HSS 18%W	ID No. HS
210	30	111922	8118213
210	35	111954	8118215
230	30	111923	8118233
230	35	111955	8118235
240	30	111924	8118243
240	35	111956	8118245
250	30	119201	8118253
250	35		8118255
260	30	111925	8118263
260	35	111957	8118265
300	30	111926	8118303
300	35	111958	8118305
310	30	111927	8118313
310	35	111959	8118315
350	30	111928	8118353
350	35	111960	8118355
400	30	111929	8118403
400	35	111961	8118405
410	30	111930	8118413
410	35	111962	8118415
450	30		8118453
450	35		8118455
500	30	111931	8118503
500	35	111963	8118505
510	30	111932	8118513
510	35	111964	8118515
530	30	111934	8118533
530	35	111966	8118535
600	30	111935	8118703
600	35	111967	8118705
610	30	111936	8118613
610	35	111968	8118615
640	30	111938	8118643
640	35	111970	8118645
710	30	111939	8118713
710	35	111971	8118715
810	30	111940	8118813
810	35	111972	8118815
910	30		8118913
910	35		8118915
1010	30	135318	8118113
1010	35	135106	8118115
1050	30	111942	8118143
1050	35	111974	8118145
1220	30		8118193
1220	35		8118195

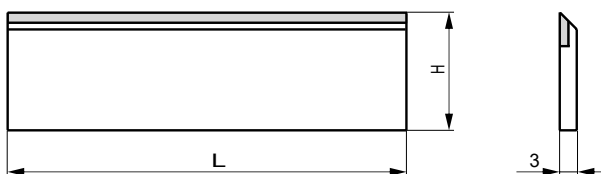

L mm	H mm	ID No.
60	30	029969
80	30	029970
100	30	029972
110	30	029973
120	30	029974
130	30	029975
150	30	029979
170	30	029981
180	30	029982
210	30	029987
230	30	029989
240	30	029991
260	30	029994
310	30	029997
330	30	002238
410	30	030001
510	30	030007
610	30	030012
630	30	030013
640	30	030014
710	30	030016
810	30	030018
310	35	030042
330	35	055837
400	35	107556
410	35	030047
500	35	030049
510	35	030050
600	35	030052
610	35	030054
630	35	030055
640	35	030057
710	35	030058
810	35	030059

Hoblovací nůž system Centrolock do hoblovacích hlav QuickClamping //

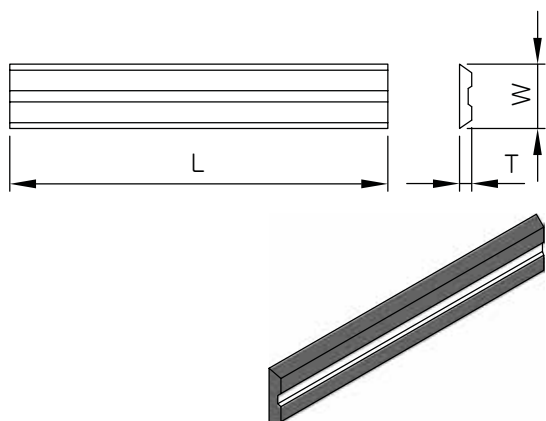

L mm	W mm	T mm	HS 18%W ID No.	HW ID No.
80	16	3	114704	100838
100	16	3	114705	055502
130	16	3	114707	055503
150	16	3	114709	100839
180	16	3	114712	100840
230	16	3	114716	054753
240	16	3	114718	055505

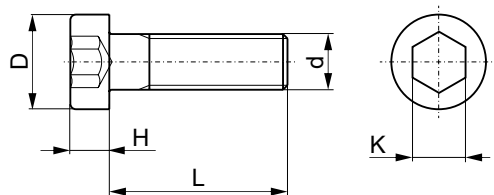

Šroub s válcovou hlavou a vnitřním šestihranem DIN 6912

d mm	L mm	D mm	H mm	K	ID No.
M4x0,7	10	6,8	2,8	2,5	710000
M4x0,7	12	6,8	2,8	2,5	710001
M4x0,7	16	6,8	2,8	2,5	710002
M4x0,7	20	6,8	2,8	2,5	710003
M4x0,7	25	6,8	2,8	2,5	710004
M4x0,7	30	6,8	2,8	2,5	710005
M4x0,7	35	6,8	2,8	2,5	710006
M4x0,7	40	6,8	2,8	2,5	710007
M5x0,8	8	8,4	3,4	3	710008
M5x0,8	10	8,4	3,4	3	710009
M5x0,8	12	8,4	3,4	3	710010
M5x0,8	16	8,4	3,4	3	710011
M5x0,8	20	8,4	3,4	3	710012
M5x0,8	25	8,4	3,4	3	710013
M5x0,8	30	8,4	3,4	3	710014
M5x0,8	35	8,4	3,4	3	710015
M5x0,8	40	8,4	3,4	3	710016
M5x0,8	45	8,4	3,4	3	710017
M5x0,8	50	8,4	3,4	3	710018
M5x0,8	55	8,4	3,4	3	710019
M5x0,8	60	8,4	3,4	3	710020
M5x0,8	70	8,4	3,4	3	710021
M5x0,8	80	8,4	3,4	3	710022
M5x0,8	90	8,4	3,4	3	710023
M5x0,8	100	8,4	3,4	3	710024
M6x1	10	9,8	4	5	710025
M6x1	12	9,8	4	5	710026
M6x1	16	9,8	4	5	710027
M6x1	20	9,8	4	5	710028
M6x1	25	9,8	4	5	710029
M6x1	30	9,8	4	5	710030
M6x1	35	9,8	4	5	710031
M6x1	40	9,8	4	5	710032
M6x1	45	9,8	4	5	710033
M6x1	50	9,8	4	5	710034
M6x1	55	9,8	4	5	710035
M6x1	60	9,8	4	5	710036
M6x1	65	9,8	4	5	710037
M6x1	70	9,8	4	5	710038
M6x1	75	9,8	4	5	710039
M6x1	80	9,8	4	5	710040
M6x1	90	9,8	4	5	710041
M6x1	95	9,8	4	5	710042
M6x1	100	9,8	4	5	710043
M6x1	110	9,8	4	5	710044

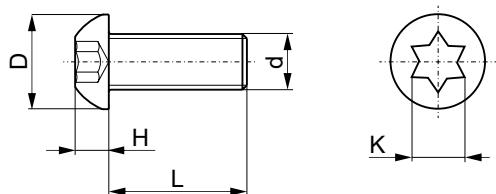

Šroub s půlkulatou hlavou a vnitřní hvězdičkou TORX

d mm	L mm	D mm	H mm	K	ID No.
M4x0,7	5	7,6	2,2	TX20	710047
M4x0,7	6	7,6	2,2	TX20	710048
M4x0,7	8	7,6	2,2	TX20	710049
M4x0,7	10	7,6	2,2	TX20	710050
M4x0,7	12	7,6	2,2	TX20	710051
M4x0,7	14	7,6	2,2	TX20	710052
M4x0,7	16	7,6	2,2	TX20	710053
M4x0,7	20	7,6	2,2	TX20	710054
M4x0,7	25	7,6	2,2	TX20	710055
M5x0,8	6	9,2	2,7	TX25	711048
M5x0,8	8	9,2	2,7	TX25	711049
M5x0,8	10	9,2	2,7	TX25	711050
M5x0,8	12	9,2	2,7	TX25	711051
M5x0,8	14	9,2	2,7	TX25	711052
M5x0,8	16	9,2	2,7	TX25	711053
M5x0,8	20	9,2	2,7	TX25	711054
M5x0,8	25	9,2	2,7	TX25	711055
M6x1	16	9	3,5	TX25	710056
M6x1	18	9	3,5	TX25	710057
M6x1	20	9	3,5	TX25	710058
M8x1,25	20	12	4	TX40	710096

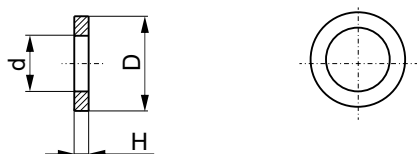

Podložka pro šroub 710056, 710057, 710058

d mm	D mm	H mm	ID No.
6	9	1	710059
8	12	1	710097

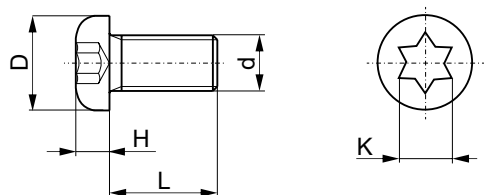

Šroub s půlkulatou hlavou a vnitřní hvězdičkou TORX

d mm	L mm	D mm	H mm	K	ID No.
M3,5x0,6	6	5,9	2,4	TX15	710062
M3,5x0,6	5	5,9	2,4	TX15	710118

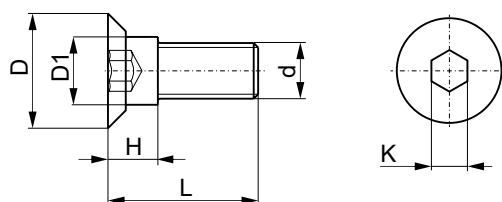

Šroub se zápustnou hlavou s dříkem a vnitřním šestihranem

d mm	L mm	D mm	D1 mm	H mm	K	ID No.
M5x0,8	13,5	9,5	6	4,9	3	710076

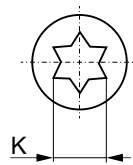
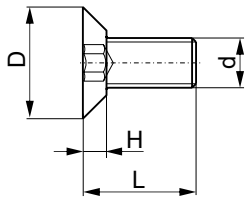

Šroub se zápustnou hlavou a vnitřní hvězdičkou TORX

d mm	L mm	D mm	H mm	K	ID No.
M4x0,7	10	7,5	2,3	TX15	710063
M5x0,8	8,5	8,8	1,8	TX20	710064
M5x0,8	10	8,9	2,1	TX20	710086
M6x0,5	4,8	9,8	2,6	TX20	710065
M6x1	10	9,8	2,6	TX20	710066
M6x1	12	9,8	2,6	TX20	710067
M6x1	14	9,8	2,6	TX20	710068
M6x1	16	9,8	2,6	TX20	710069
M6x1	20	9,8	2,6	TX20	710070
M6x1	25	9,8	2,6	TX20	710071
M6x1	30	9,8	2,6	TX20	710072

Šroub se zápustnou hlavou a vnitřní hvězdičkou TORX použitý v kombinaci s maticemi 710082, 710083, 710084 u označených položek

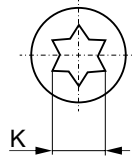
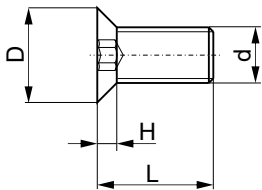

d mm	L mm	D mm	H mm	K	ID No.
M4x0,5	3,2	6	1,5	TX10	710077
M4x0,5	4,3	6	1,5	TX10	710060
M4x0,5	6,3	6	1,5	TX10	710061

Zápustná matice M4 použitý v kombinaci se šrouby 710060, 710061, 710077

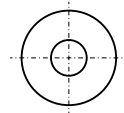
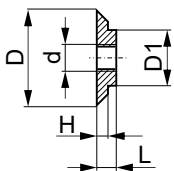

d mm	L mm	D mm	D1 mm	H mm	ID No.
M4x0,5	1,6	9,9	8,4	0,6	710082

Zápustná matice M4 použitý v kombinaci se šrouby 710060, 710061, 710077

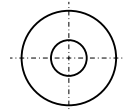
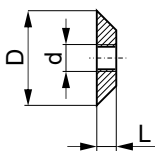

d mm	D mm	L mm	ID No.
M4x0,5	11,9	1,7	710083

Zápustná matice M4 použitý v kombinaci se šrouby 710060, 710061, 710077

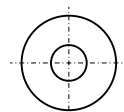
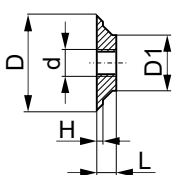

d mm	L mm	D mm	D1 mm	H mm	ID No.
M4x0,5	2,2	11,8	8,4	0,7	710084

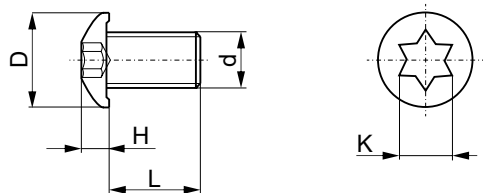

Šroub s půlkulatou hlavou a vnitřní hvězdičkou TORX

d mm	L mm	D mm	H mm	K mm	ID No.
M4x0,7	4	9	2,3	TX15	710079
M4x0,7	6	9	2,3	TX15	710080
M4x0,7	9	9	2,3	TX15	710081

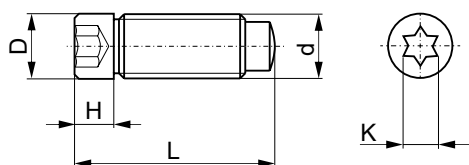

Stavěcí šroub s čípkem a dříkem s vnitřní hvězdičkou TORX

d mm	L mm	D mm	H mm	K mm	ID No.
M4x0,7	20	3,8	5	TX8	710075
M5x0,8	20	4,8	5	TX15	710074
M6x1	20	5,8	5	TX20	710073

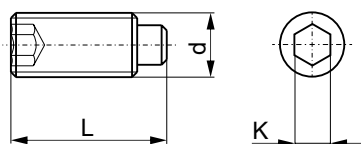

Stavěcí šroub s čípkem a vnitřním šestihranem

d mm	L mm	K mm	ID No.
M8x1	16	4	710090
M8x1	20	4	710045
M10x1	20	5	710046
M10x1	30	5	710091

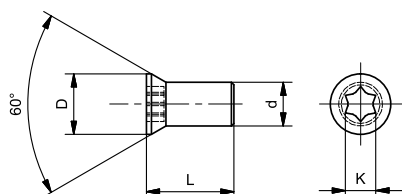
šroub se zápustnou hlavou a vnitřní hvězdičkou TORX
použití v kombinaci se systémem StabilHead

d mm	L mm	D mm	K mm	ID No.
M5x11.5	11.5	6.9	TX20	710087

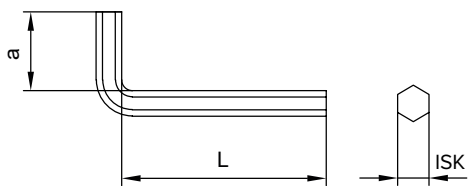

ISK mm	L mm	a mm	ID No.
2,5	111	17	710202
3	123	19	710203
4	138	25	710204
5	156	28	710205
6	176	30	710206

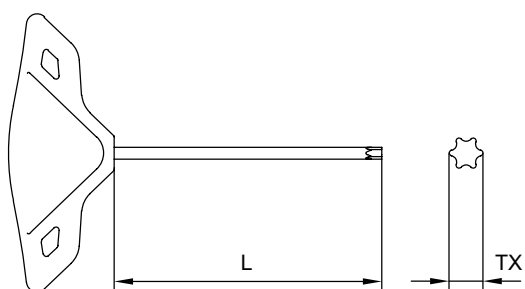

TX	L mm	ID No.
8	87	710218
9	107	710219
10	107	710220
15	127	710235
20	141	710240
25	142	710245